

**Product:**

Rear Trailing Arm

**Part Number:**

1410118

**Applications:**

Chevrolet Camaro, 2010-Present

**Description:**

The Rear Trailing Arm Kit is designed to replace the OEM rear trailing arm. The Pfadt Rear Trailing Arm reduces deflection and increases strength of the suspension in extreme performance applications.

**What's in the box:**

- (2) – Pfadt Trailing Arms
- (1) – Package of 8 polyurethane bushings and 2 grease packets
- (1) – Package of 4 anodized aluminum sleeves

**Difficulty of Installation:** **Beginner** |-----x-----| **Advanced**

**Reason:** This product is a very easy install.

**Expected Installation Time:** 1 Hour and 45 Minutes

**Recommended Tools:**

- 18mm Socket and Ratchet
- 18mm Box End Wrench
- Torque Wrench
- Press

## Installation Procedure

### OEM Part Removal

Safely lift and support the rear of the car and remove rear wheels.

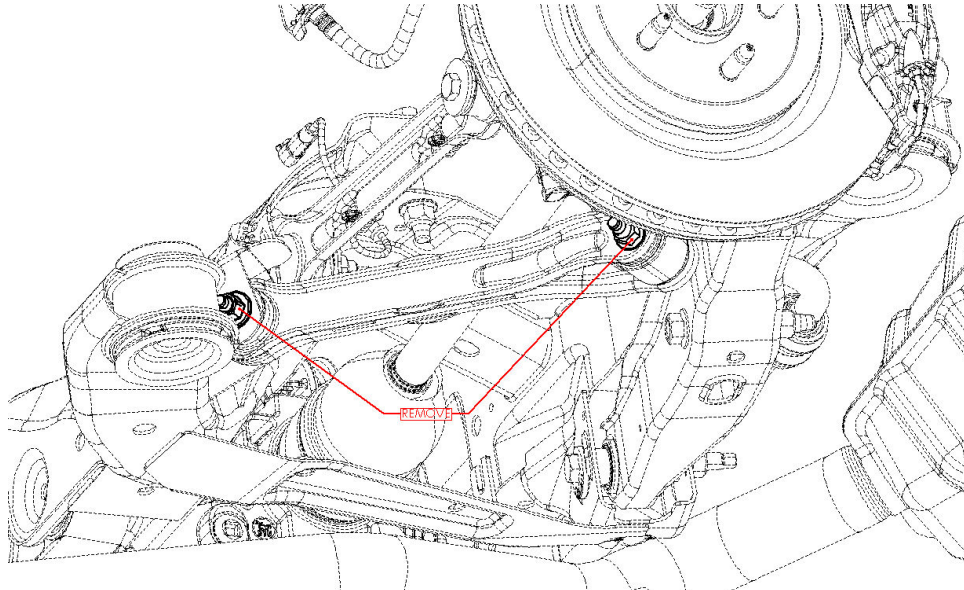

Using the 18mm socket and 18mm box end wrench remove the two bolts and nuts holding each trailing arm in the car.

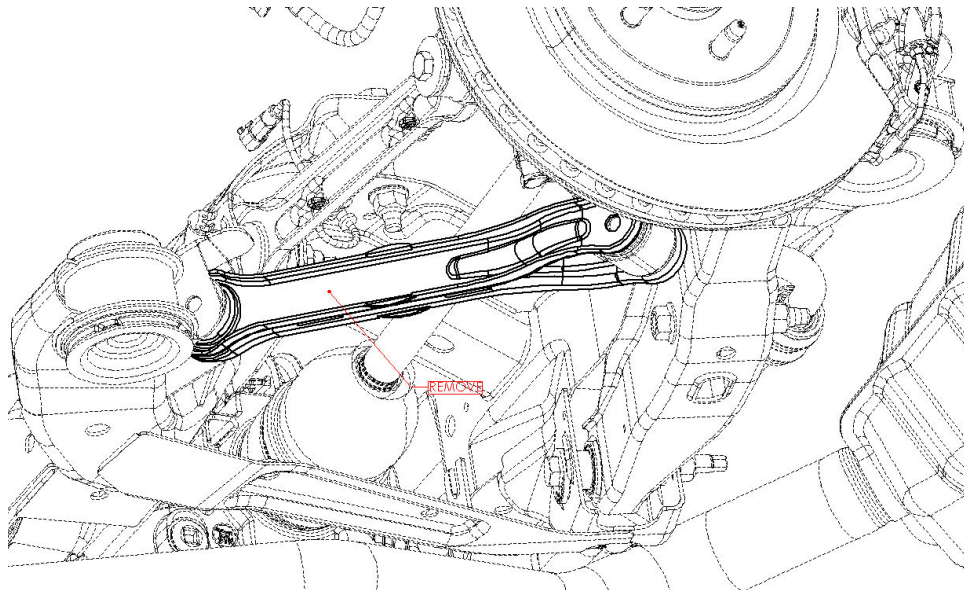

Remove the trailing arm and press bushing from upright.

## New Part Installation

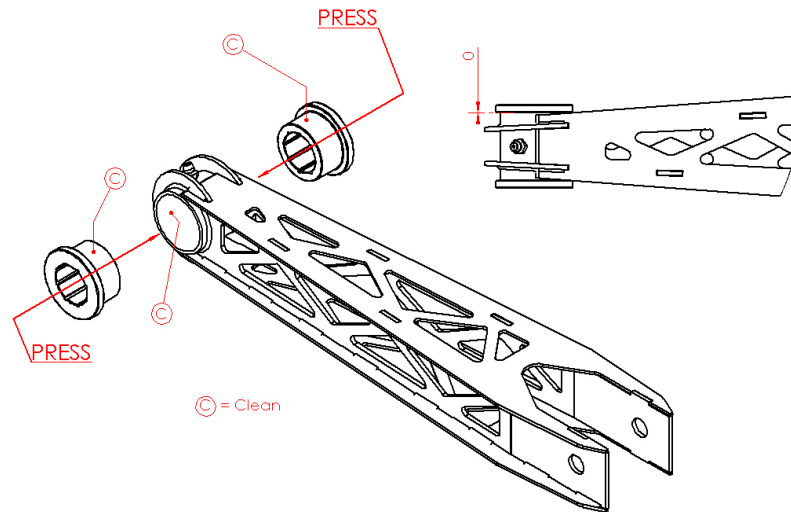

Clean the surfaces of the trailing arm and bushing as shown. Press the polyurethane bushings into the trailing arm. The flange faces should be touching the sides of the trailing arm.

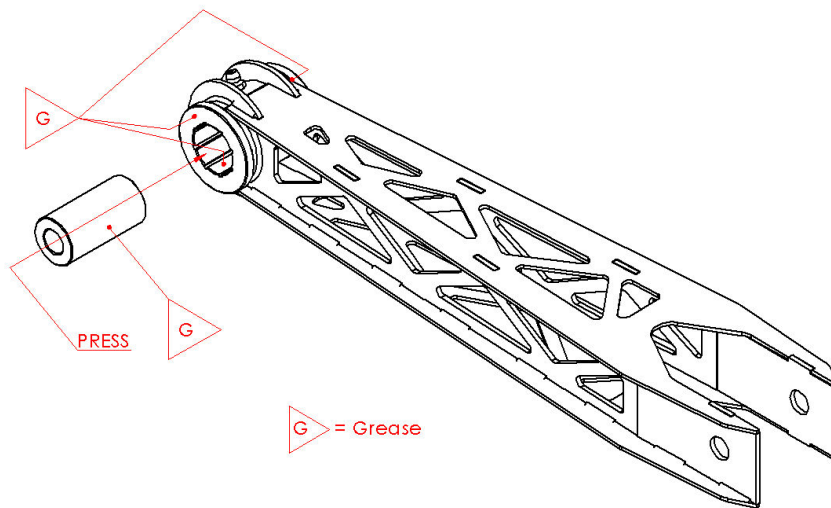

Coat the outside of the aluminum sleeve. Coat the flange and inside of each bushing, filling the grooves, with the provided grease.

Repeat this bushing installation procedure for the upright bushings.

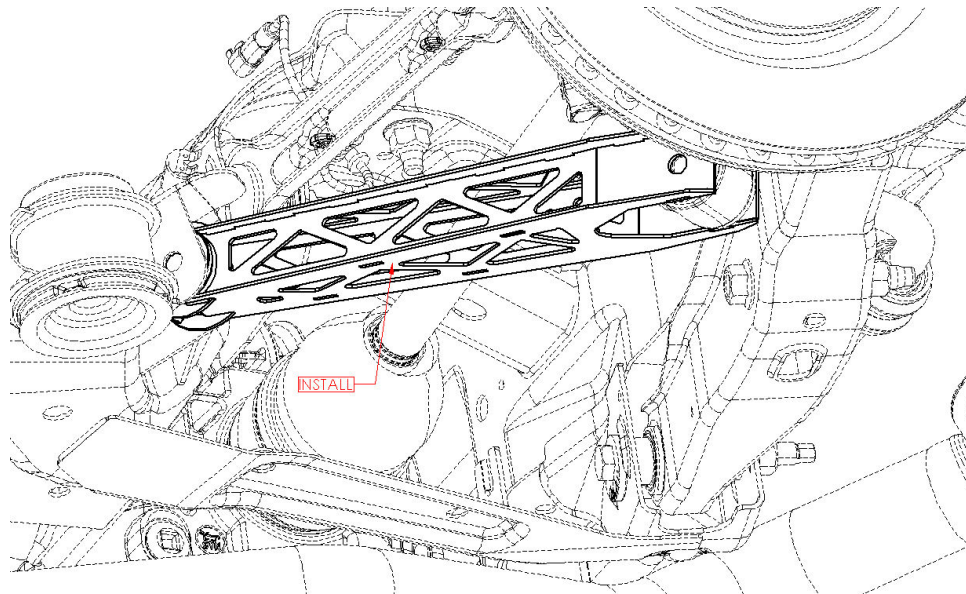

Install new trailing arm.

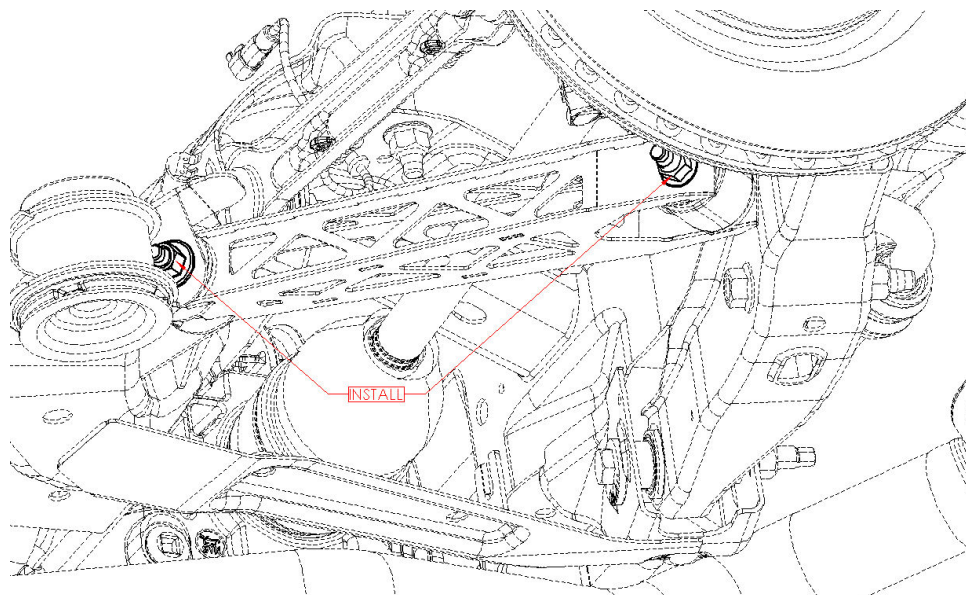

Using the 18mm socket and 18mm box end wrench reinstall the two bolts and nuts attaching the trailing arm to the chassis and torque.

At this point take a moment to check each bolt that was removed has been tightened.

Reinstall the wheels and safely lower car. Torque lug nuts.  
Test drive and Enjoy!

#### **Fastener Torque**

Trailing Arm Bolts, M12

71 N-m (52 ft-lbs)

Please contact Pfadt Customer Support with any questions!



2315 Decker Lake Blvd.  
Salt Lake City, UT 84119

888-972-2464  
[www.PfadtRacing.com](http://www.PfadtRacing.com)